



Internal Use Only

<http://biz.lgservice.com>

Multi Air Conditioner

SVC MANUAL(Exploded View)

**MODEL : A2UW146FA6
MU2M15[UL1]**

CAUTION

Before Servicing the unit, read the safety precautions in General SVC manual.
Only for authorized service personnel.

1. Specification

Outdoor Unit			A2UW146FA6 MU2M15[UL1]
Nominal Capacity (Min~Rated~Max)	Cooling	kW	1.35~4.10~4.69
		Btu/h	4,600~14,000~16,000
	Heating	kW	1.41~4.70~5.27
		Btu/h	4,800~16,000~18,000
Nominal Input (Min~Rated~Max)	Cooling	kW	0.38~1.07~1.70
	Heating	kW	0.45~1.12~1.80
Energy label			A/A
Testing Combination			CS07AQ NBO * 2EA
Running Current (Min~Rated~Max)	Cooling	A	1.6~4.9~7.6
	Heating	A	1.7~5.1~8.2
Starting Current	(Cooling/Heating)		8/8
Circuit Breaker		A	15
Power Supply		Ø / V / Hz	1 / 220~240 / 50
Power Supply Cable (outdoor)		No.* mm2	3*2.5
Power and transmission cable (outdoor to indoor)		No.* mm2	4*0.75 (including earth)
Power and transmission cable (BD to indoor)		No.* mm2	-
Dimensions	W*H*D	mm(inch)	770*545*288 (30.3*21.5*11.8)
Net Weight		kg(lbs)	39(86)
Gross Weight		kg(lbs)	41.5(91.5)
Max. Number of Connectable Indoor Units			2
Compressor #1	Type		Rotary
	Qty x Model		1 x GKT141DAA
	Motor Type		BLDC
	Oil Charge volume	cc	570
	Oil Type		FVC68D
Refrigerant	Cycle A Charge (at 7.5m)	g(oz)	1,300(42.3)
	Type		R410A
	Control		EEV
Heat Exchanger	Rows x Column x FPI		2R x 24C x 18
Fan	Defrosting Method		Reversing cycle
	Capacitor	µF/Vac	-
	Drive		Direct
	Discharge direction	Side / Top	Side
	Air Flow Rate	CMM(CFM)	28.2(995)
Noise Level(H/L)	Sound Pressure at 1m	dB(A)+3	50
Piping connections	Liquid	mm(inch)	6.35(1/4)*2EA
	Gas	mm(inch)	9.52(3/8)*2EA
Max. Interunit	Total of Each Room	m	30
Piping Length	Main Piping	m	20
Max. Elevation	Indoor Unit~Outdoor Unit	m	15
	Indoor Unit~Indoor Unit	m	7.5

Note :

1. Capacities are based on the following conditions:

Cooling : - Indoor Temperature 27°C(80.6°F) DB / 19°C(66.2°F) WB

- Outdoor Temperature 35°C(95°F) DB / 24°C(75.2°F) WB

Heating : - Indoor Temperature 20°C(68°F) DB / 15°C(59°F) WB

- Outdoor Temperature 7°C(44.6°F) DB / 6°C(42.8°F) WB

Piping Length - Interconnecting Piping Length 7.5m

- Level Difference of Zero.

2. Due to our policy of innovation some specifications may be changed without notification.

3. At least two indoor units should be connected.

4. Wiring cable size must comply with the applicable local and national code.

Conversion Formula

kW = Btu/h × 0.0002931

CFM = CMM × 35.3

2. List of Functions

Outdoor Functions		A2UW146FA6
Reliability	Defrost / Deicing	O
	High Pressure Switch	X
	Low Pressure Switch	X
	Phase protection	X
	Restart Delay (3-minutes)	O
	Self Diagnosis	O
	Soft Start	O
	Test Function	O
Convenience	Auto operation(Artificial intelligence)	O
	Auto Restart Operation	O
CAC Network Function	Central control(LGAP)	X
	PDI(Power Distribution Indicator)	X
	PI485	X
Special function kit	Low ambient operation	-
Others	Thermistor	-

O : Applied X : Not applied - : No relation

Option : Model name & price are different according to options, and assembled in factory with main unit.

Accessory : Installed at field, ordered and purchased separately by the corresponding model name, supplied with separate package

3. Piping Diagrams

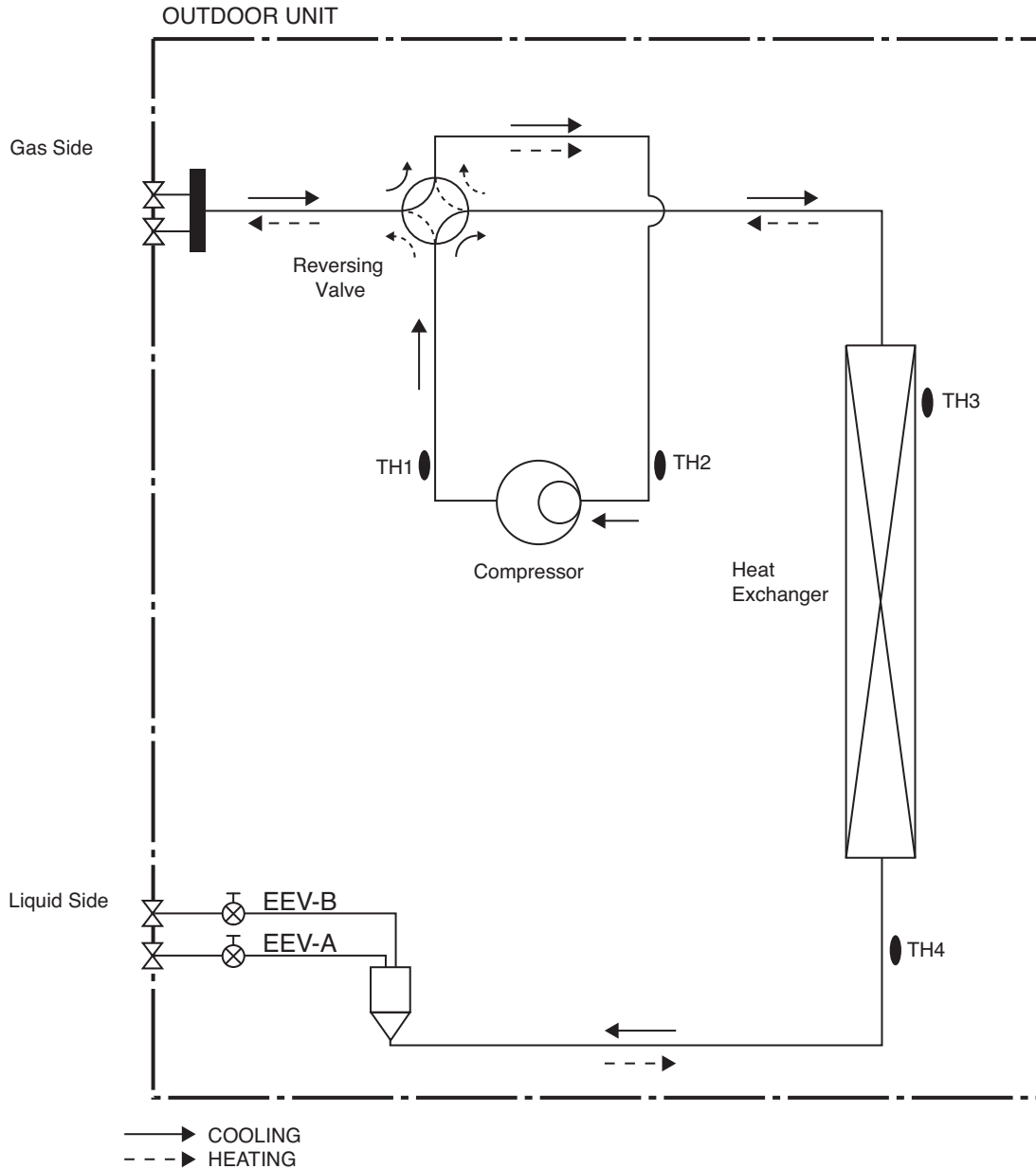

LOC.	Description	PCB Connector
TH1	Thermistor for discharge pipe temperature	CN_TH2
TH2	Thermistor for suction pipe temperature	CN_TH2
TH3	Thermistor for outdoor air temperature	CN_TH1
TH4	Thermistor for condensing temperature	CN_TH1

4. Wiring Diagrams

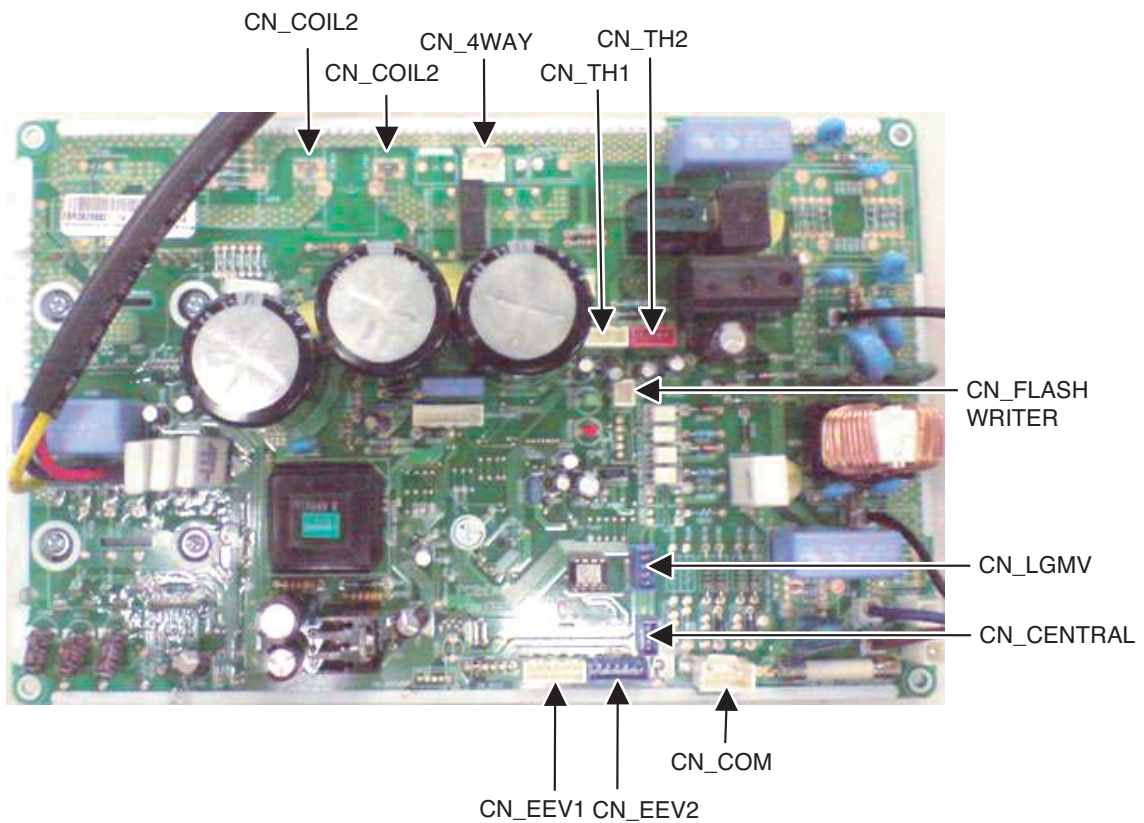
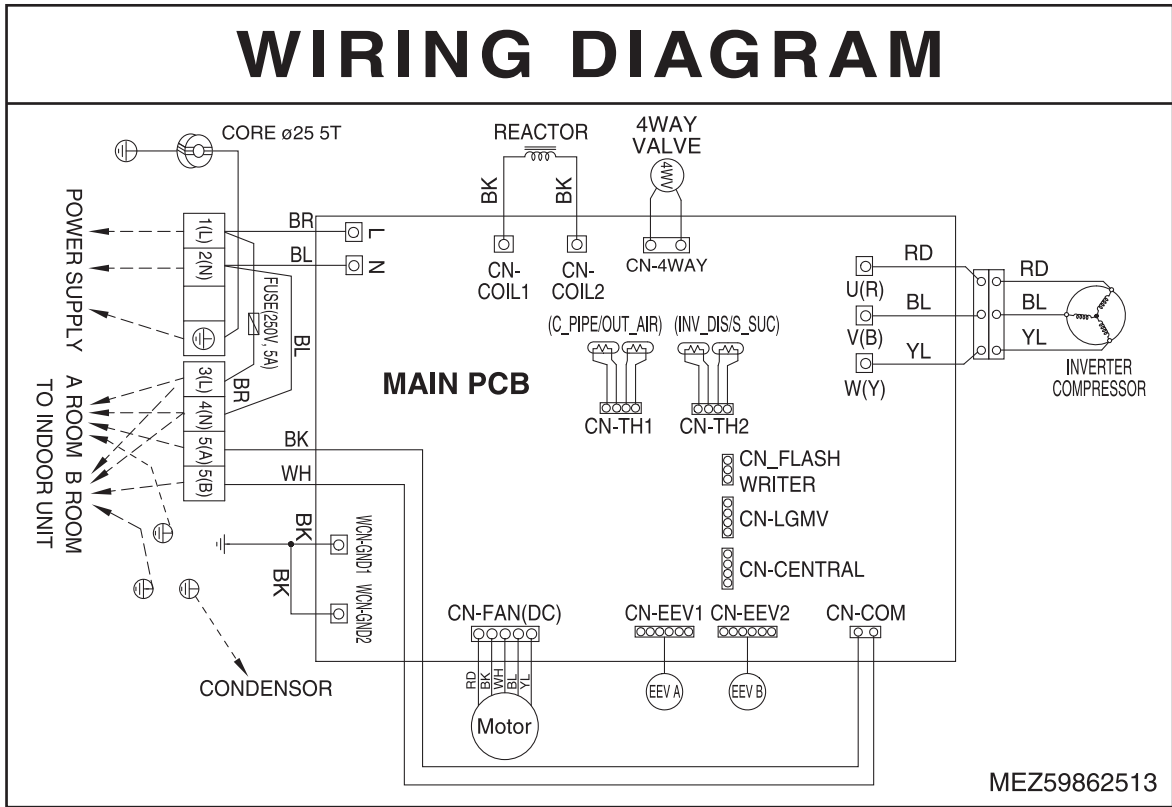

5. Exploded View

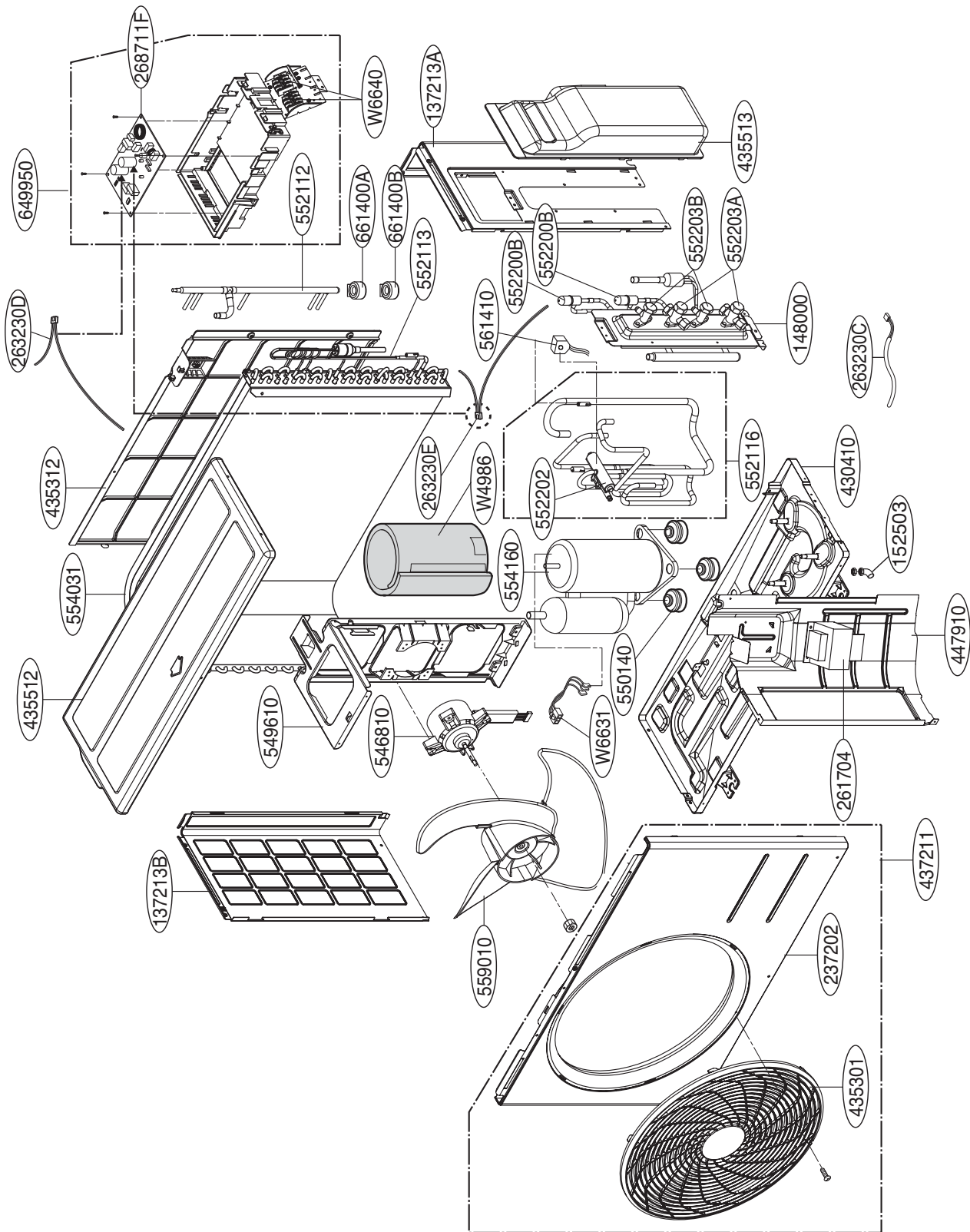

Note) * Please ensure GCSC since the replacement parts may be changed depending upon the buyer's request.
 Please check the correct parts in View RPL(Replacement Part List) on GCSC.
 (GCSC Website <http://biz.lgservice.com>.)



P/NO : MFL61921720

NOVEMBER,2010